

Researches on the photoconductivity and UV-visible absorption spectra of the first C₆₀-chemically modified poly(N-vinylcarbazole)

Yu Chen¹, Rui-Fang Cai¹, Zu-En Huang^{1,*}, Xue Bai¹, Bo-Cheng Yu¹, Wei Jin², Dao-Cheng Pan², Shao-Tai Wang²

¹ Department of Chemistry, Fudan University, Shanghai 200433, People's Republic of China

² Department of Applied Chemistry, Shanghai Jiao Tong University, Shanghai 200240, People's Republic of China

Received: 2 August 1995/Revised version: 26 September 1995/Accepted: 27 September 1995

Summary

Addition of C₆₀ moiety, a powerful electron acceptor to poly(N-vinylcarbazole) by chemical reaction results in the marked enhancement in photoconductivity relative to pure PVK and C₆₀/PVK mixtures (C₆₀-doped PVK). The photo-induced discharge rates for pure PVK, C₆₀-chemically modified PVK(C₆₀-PVK copolymer) and C₆₀-doped PVK under the same experimental conditions are found in the following order: C₆₀-PVK copolymer > C₆₀-doped PVK > pure PVK. The photoconductive performance in C₆₀-PVK copolymer is closely related to fullerene level. The C₆₀-PVK copolymer, which has a visibly earthy yellow cast when compared with the unreacted polymer, has a new structure in the UV-Vis absorption spectrum with the active range extending from about 280 to 870 nm. A qualitative comparison of the submicro-morphological structures for PVK, C₆₀, C₆₀-PVK and C₆₀-doped PVK is given.

Introduction

Photoconductivity is one of the commercially significant photoresponses of polymeric systems^(1,2). It is fundamental to photodetection and electrostatic imaging, as well as a number of related processes. The enhancement of the photoconductivity of poly(N-vinylcarbazole) (PVK, electron donor) film by doping with fullerenes (A mixture of C₆₀ and C₇₀) has been reported by Y. Wang⁽³⁾. It was said that the performance of this material, with the active spectral range extending from about 280 to 680 nm, is comparable with some of the best photoconductors available commercially, such as thiapyrylium dye aggregates. Similar doping effects of fullerene on the photoconductivity are also reported on phenylmethylpolysilane (PMPS)⁽⁴⁾, poly[2-methoxy,5-(2'-ethylhexyloxy)-p-phenylene vinylene] (MEH-PPV)^(5,6) and poly(3-octylthio-phenylene) (P3OT)⁽⁶⁾. The photoconductivity is due to the fullerene on the charge generation and the charge transport processes in the polymeric system⁽⁷⁾. These results show possibilities for the development of fullerene-based polymeric photoconductors. However, to date all researchers only focus their attention on the photoconductive investigations for

* Corresponding author

the simple blends of fullerene and polymers. Little information is available on the effect of chemical modification (fullerene) on the photoconductivity of PVK. As a matter of fact, photoconductivity and its component processes, charge generation and charge transport, can be controlled by chemical modification of polymers. Meanwhile, chemical modification also is useful in improving the mechanical properties, particularly, solubility, film formation, flexibility, and impact resistance of photoconductive polymer systems⁽¹⁾.

This paper first reports the effect of C₆₀-chemical modification on the UV-Vis absorption spectra and photoconductivity of PVK. The results show that addition of C₆₀ moiety, a powerful electron acceptor (EA=2.6~2.8 eV) to PVK by chemical reaction results in the marked enhancement of photoconductivity relative to pure PVK and C₆₀-doped PVK. The UV-Vis absorption spectral range associated with the charge photogeneration process extends from about 280 to 870 nm.

Experimental

A pure C₆₀ sample was synthesized and purified according to literature^(8,9), solvent residues were removed by vacuum-drying at 200°C for several hours. HPLC analysis shows C₆₀ in a purity of 99.5%. The synthesis and characterization of C₆₀-chemically modified poly(N-vinylcarbazole) have been reported in more detail previously⁽¹⁰⁾. Scheme I gives its typical synthetic method. The resultant substance's solubility in some organic solvents was found in the following order: DMF>CS₂,CHCl₃>THF>>C₆H₆.

Scheme I

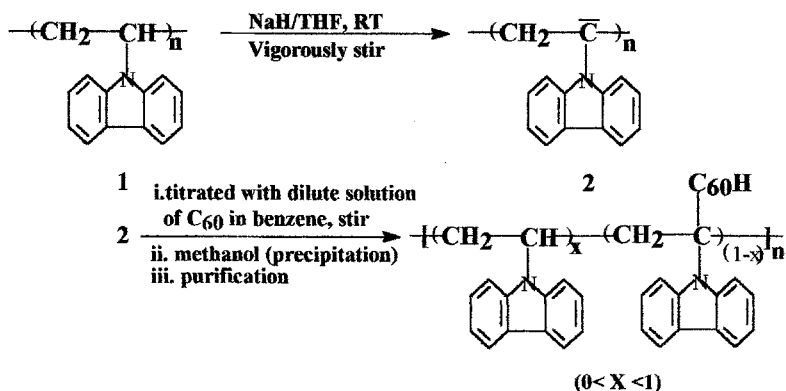

UV-Visible absorption spectra were measured on a Shimadzu UV-240 spectrophotometer using redistilled paraffin oil as reference standard. The surface topographical structures of the sample C₆₀, PVK, C₆₀-PVK copolymer and C₆₀-doped PVK were studied by Hitachi HO-ΠB scanning electron microscope (SEM). The photoconductivity of the samples: PVK, 3.85% C₆₀-PVK, 12.80% C₆₀-PVK and 3.85% C₆₀-doped PVK were measured on a Shishido Type S-5109 static electrometer. A halotungsten lamp (150 W) is used as the light source. The light intensity used is 180 lux. The sample film, deposited on an electrically grounded aluminium substrate, is first coronacharged (positively or negatively) in the dark. The amount of surface charge is detected by an electrostatic voltmeter.

On exposure to light, the photogenerated electrons and holes migrate to the surface, recombine with surface charges and discharge the surface potential. This photoinduced discharge process is the basis of xerography.

Result and Discussion

The C_{60} -chemically modified PVK has a visibly earthy yellow cast when compared with the unreacted polymer and the reason for this is apparent in the UV-Visible absorption spectra. It is seen that poly(*N*-vinylcarbazole) is essentially transparent at wavelengths longer than 350 nm, its main UV-Vis bands occur at 195(vs), 225(ms, shoulder peak), 268(vw), 306(vw), 325(vw), 336(vw), and 355(vw) nm. However, the fullerenated polymer has new structure in the absorption spectrum in which the main bands occur at 215(ms), 265(s), 298(ms), 335(vw), and 345(ms) nm and extends the active range from about 280 to 870 nm (For C_{60} -doped PVK⁽³⁾, the absorption range extended only from about 280 to 680 nm). The absorption in the visible region is essentially determined by the fullerene level in the copolymer, i.e. increasing the fullerene level should further enhance the absorbancy at longer wavelengths. Owing to a " charge-transfer " interaction between: (a) C_{60} on the main chain backbone and adjacent carbazole groups, (b) positively charged carbazyl resulting from charge transfer towards C_{60} , and near-neighboring electron-rich groups of the resultant copolymer(see Scheme II). In addition, it is also found that the absorption spectra of the C_{60} -PVK copolymer

Scheme II

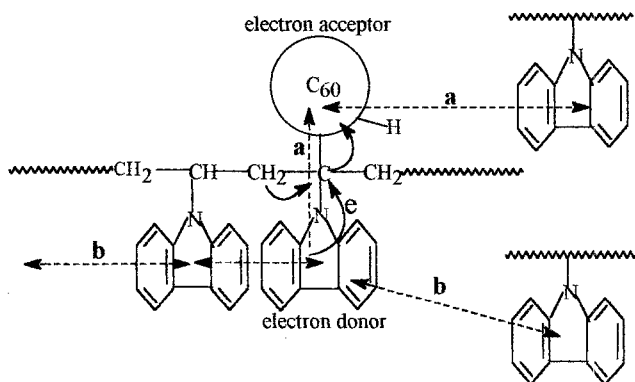

and C_{60} have only a sharp peak at 215 nm in common, meanwhile, the other five peaks at 260 (s), 376 (ms), 448 (w), 495 (ms), and 615 (w) nm using redistilled paraffin oil as r.s. with respect to pure C_{60} were not observed in the copolymer.

Figure 1 compares the submicro-morphological structure of C_{60} -PVK copolymer containing 3.85% of C_{60} with that of C_{60} , PVK and C_{60} -doped PVK. The morphology, a single structure of an elongated ellipsoidal sediment, of C_{60} -PVK copolymer is very similar to that of coral reef, and differs greatly from that of C_{60} , PVK, or C_{60} -doped PVK. As shown in Figure 1d, although the doping of hole transporting, donor PVK with electron acceptor(C_{60}) results in extended spectral sensitivity as well as enhanced photogenerated efficiency^(1,3), there are,

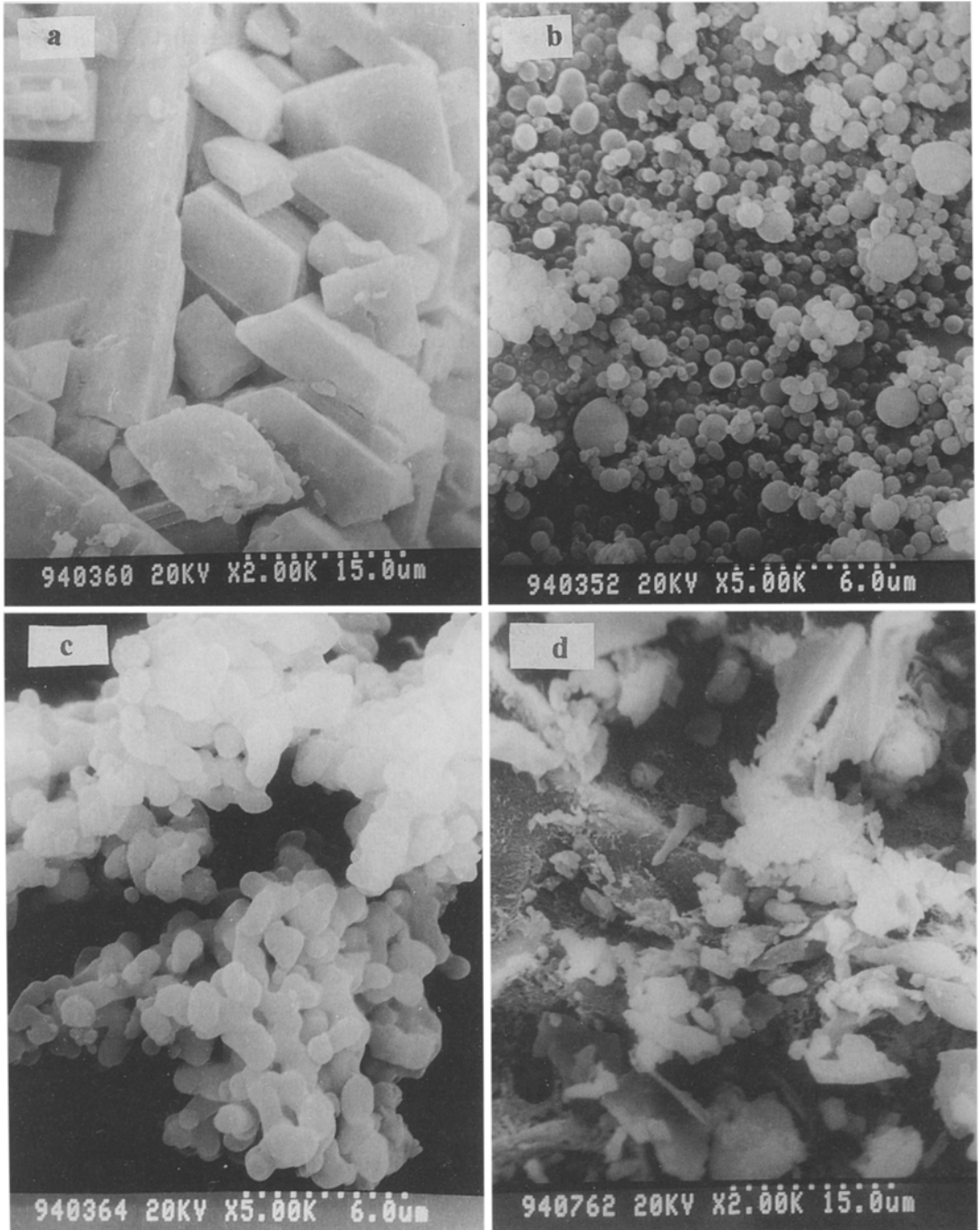

Figure 1. Scanning electron micrographs of (a) C₆₀; (b) PVK; (c) C₆₀-PVK copolymer containing 3.85% of C₆₀; (d) C₆₀-doped PVK containing 12.28% of C₆₀.

however, problems associated with this approach. These problems stem from the tendency for the dopant molecules to aggregate in the solid state⁽¹⁾, leading to difficulty in achieving homogeneous dispersions and ultimately phase separation at high loadings. This might be one of the important reasons for resulting in difference in the photoconductivity for copolymer and mixtures discussed as follows. Chemical modification of the polymer matrix can circumvent these problems.

A qualitative comparison of the photo-induced discharge curves for pure PVK, C₆₀-PVK copolymer and C₆₀-doped PVK under the same experimental conditions is shown in Figure 2. As we expected, addition of C₆₀ moiety, a powerful electron

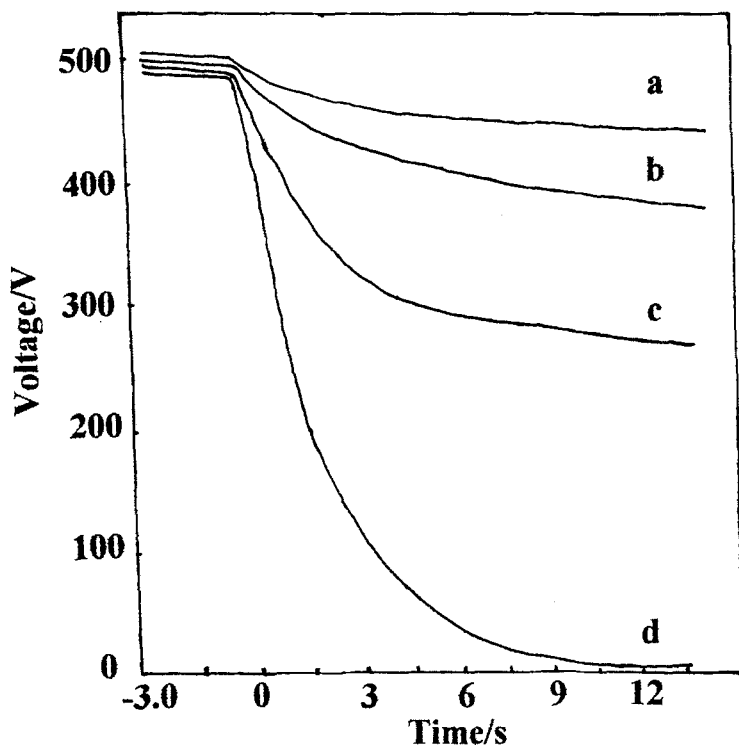

Figure 2 A qualitative comparison of the photo-induced discharge curves for (a) pure PVK; (b) 3.85% C₆₀-doped PVK; (c) 12.28% C₆₀-PVK copolymer; (d) 3.85% C₆₀-PVK copolymer under the identical experimental conditions.

acceptor to PVK by chemical reaction results in the marked enhancement in photoconductivity relative to pure PVK and C₆₀-doped PVK. The photoconductive performance in copolymer is closely related to fullerene level. In our previous paper⁽¹⁰⁾, we reported the effect of UV-irradiation (A W-Germany Hereaus type high-pressure mercury lamp is used as the light source. ESR spectra were recorded on Bruker ER200D-SRC spectrometer, and g-values were determined by calibration to DPPH.) on the paramagnetic electronic structure of

C_{60} -PVK copolymer. It was found that the role of rapid photoelectron transfer and exchanges between positively charged carbazole groups and adjacent electron-rich carbazole groups is in existence under the action of UV-light. Therefore, A "Charge-transfer" interaction between the positively charged carbazyl resulting from charge transfer towards C_{60} , and near-neighboring carbazole moieties of the resultant copolymer (see Scheme II) may be credited with bringing about the enhanced photoconductivity relative to PVK itself via increased photogeneration of charge carriers^(11,12). The photo-induced discharge rates of pure PVK, C_{60} -PVK and C_{60} -doped PVK are found qualitatively in the following order: 3.85% C_{60} -PVK >> 12.28% C_{60} -PVK > 3.85% C_{60} -doped PVK > pure PVK under the same experimental conditions. This result indicated that chemical modification is very useful in enhancing the photoconductivity of polymers. Further studies on the photoconductive properties of C_{60} -chemically modified poly(N-vinylcarbazole) and its derivatives are currently being investigated.

Acknowledgment We thank National Natural Science Foundation of China and Science Foundation of Shanghai Committee of Science and Technology for financial support of this work. We are also indebted to Master Xin-Wei PAN for her generous help.

Reference

1. Gibson HW (1984) *Polymer* 25:3
2. (a) Naarmann H and Strohrriegel P (1992) *Handbook of Polymer Synthesis*(Ed. Kricheldorf HR) Dekker, New Yourk. Part B:1409 (b) Gražulevičius JV, Kavaliūnas R and Unžėnas A (1990) *Proc 2nd Int Conf Elec Opt and Acoust Prop Polym*, Canterbury, P.1
3. Wang Y (1992) *Nature* 356:585
4. Wang Y, west R and Yuan CH (1993) *J Am Chem Soc* 115:3844
5. Smilowitz L, Sariciftci NS, Wu R, Gettinger C, Heeger AJ, and Wudl F (1993) *Phys Rev B* 47:13835
6. Lee CH, Yu G, Moses D, Pakbaz K, Zhang C, Sariciftci NS, Heeger AJ, and Wudl F (1993) *Phys Rev B* 48:15425
7. Watanabe A and Ito O (1994) *J Chem Soc Chem Commun* 1285
8. Krättschmer W, Lamb LD, Fostiropoulos K, Huffman DR (1990) *Nature* 347:354
9. Isaacs L, Wehrig A, Diederich F (1993) *Helv Chim Acta* 76:1231
10. (a) Chen Y, Huang ZE, Cai RF (1995) *J Polym Sci B Polym Phys*, in press. (b) Chen Y, Cai RF, Huang ZE, Bai X, Chen SM, Yan XM (1995) *Solid State Commun*, in press.
11. Morimoto K, Inami A, and Minobe A (1967) *Japan Patent* XX,049
12. Inami A and Morimoto K (1968) *German Patent* 1,264,954